

Adjustable topstop for ConSet® model 501-X1 column

1. Adjust the bracket length "X" to the required stroke reduction and tighten the 2 pcs. M5 nuts. The stroke reduction can be min. 55mm and max. 400mm.

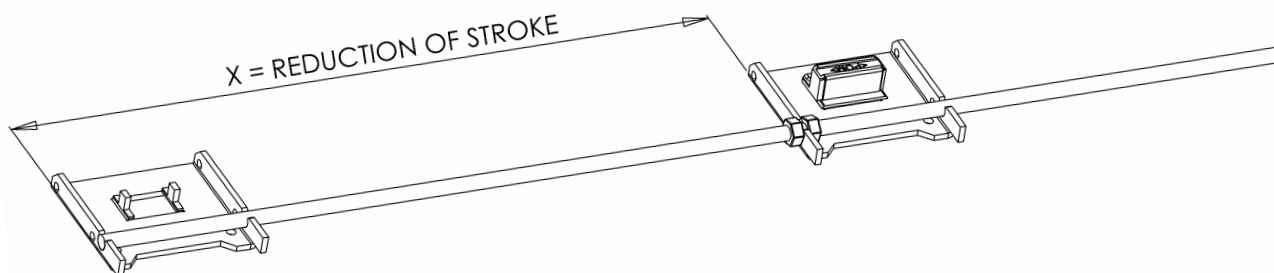

2. Cut the M5 threaded rod approx. 30-35mm from the upper M5 nut.

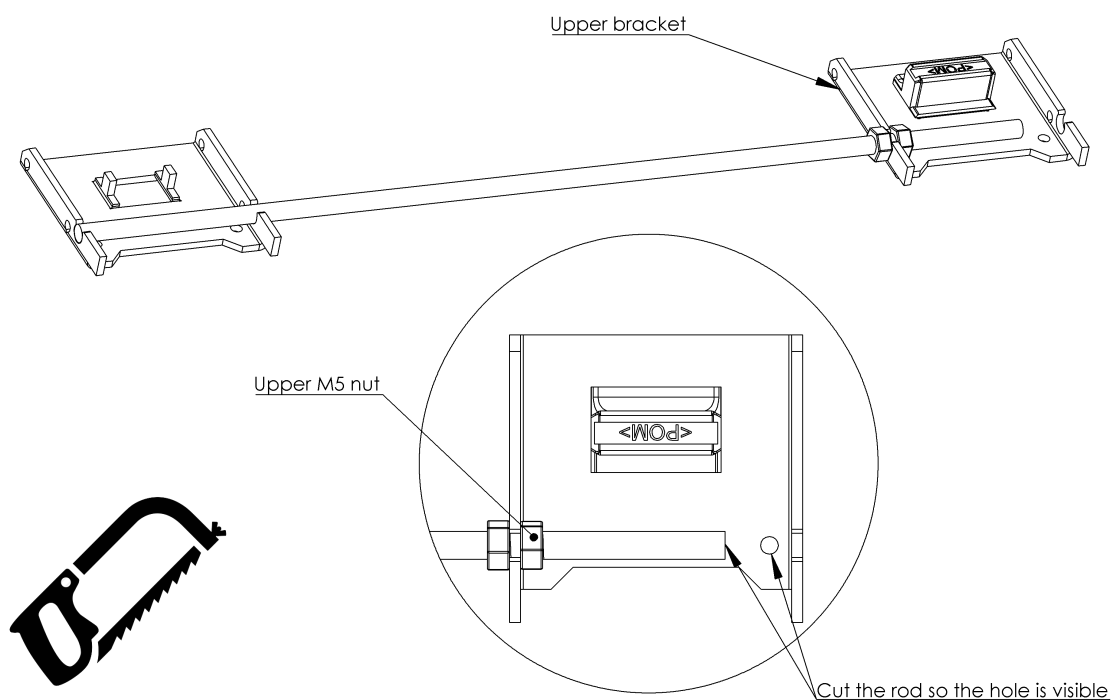

3.

Move the column to a height 10mm below the new top height.

Remove plastic cover and original endstop bracket in left side of column.
Be very careful not to drop the endstop bracket into the column. It needs a little hand force to get out.

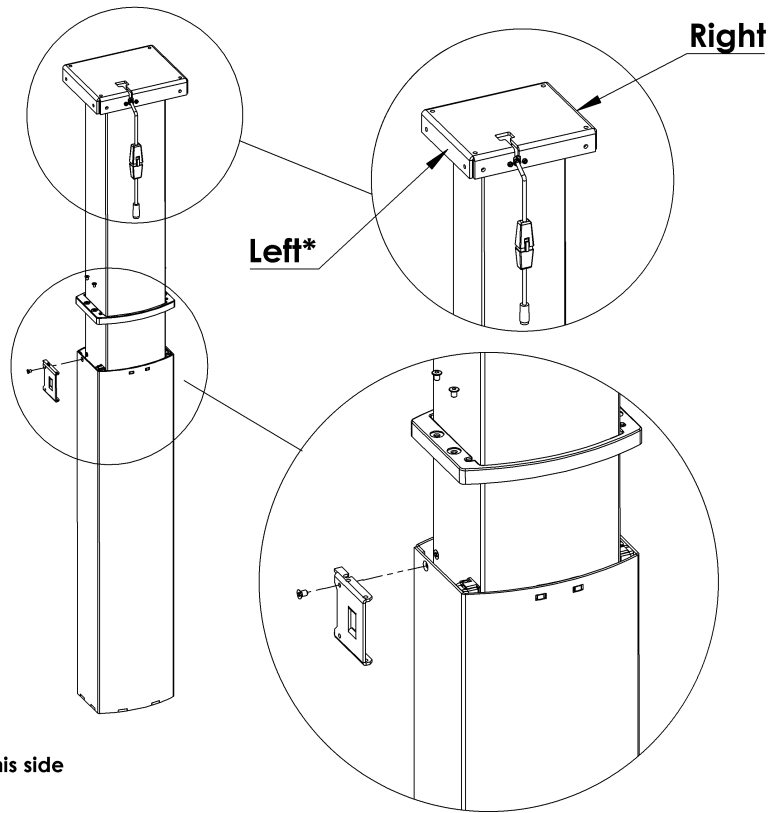

* Move endstop bracket on this side

4.

Place the adjustable topstop bracket in the column and assemble again.

If the stroke reduction is more than 250mm it is needed to 1) move up the column, 2) place the bracket and 3) move down the column again, before the bracket can be fixed.

